



**CSI:** **DIVISION: 31 00 00—EARTHWORK**  
**Section: 31 60 00—Special Foundations and Load Bearing Elements**

### Use of the Equivalency Evaluation Report:

The use of the ICC-ES equivalency evaluation report (IRC) applies to the construction of single-family houses, two-family houses (duplexes) and buildings consisting of three or more townhouse units, limited to three stories above grade plane, in accordance with the *International Residential Code*®. The ICC-ES equivalency evaluation report (IRC) evaluates designs of schematic plans, details and tables, of building products described in an ICC-ES evaluation report, to meet equivalency with the prescriptive requirements of the *International Residential Code*®.

**Report Holder:** PIN FOUNDATIONS, INC.

### Equivalency Evaluation Subject:

Special foundation designs, as an alternative, for exterior decks (covered decks, covered porches, walkways and stairways) and detached accessory structures with Diamond Pier Bearing Pins.

### Referenced ICC-ES Evaluation Report:

ESR-1895: DIAMOND PIER® DP-50 & DP-75 FOR BEARING PIN PIERS

**Product Description:** The bearing pin piers consist of a factory-fabricated, pre-cast, diamond-shaped concrete head that has a galvanized steel anchor bolt precast into the center of the top of the head; and galvanized steel bearing pins which are jobsite-installed through holes precast in the head, and driven into the underlying soil.

### Evaluated to the following IRC Sections:

- 2018, 2015, 2012, 2009 and 2006 *International Residential Code*® (IRC)  
Applicable Section(s):  
Figure R301.2(3) (Figure R301.2(4) for 2018 IRC).  
R403.1, R403.1.4.1 with exceptions as applicable.  
2018 IRC Section R507.3, 2015 IRC Section R507.8.1.

### Findings of Schematic Plans, Details and Tables:

The schematic plans, details and tables are in conformance with the prescriptive requirements of the IRC based on the submitted design calculations and the referenced ICC-ES Evaluation Report. Table 1 indicates bearing capacities for different pins in different soils. Figure 1 provides a schematic tributary area determination. Figures 2 through 6 indicate typical construction details. The schematic plans, details and tables were evaluated to the following design parameters:

#### Design Criteria:

Soils: The bearing capacity of the site soil is determined in accordance with IRC Table R401.4.1.

#### Design Loads:

Dead Loads: Floor Dead Load = 10 psf max (R301.4).

Live Loads: Floor Live Load = 40 psf max (R301.5).

Snow Loads: Ground Snow Load = 70 psf max (R301.2.3).

**Identification:**

1. The identification shall only be used on schematic plans, details and tables evaluated in this report, and each page of the schematic plans, details and tables evaluated in this report shall be identified with the ICC-ES equivalency evaluation report (IRC) number (EER-1895) watermark.
2. The report holder's contact information is the following:

**PIN FOUNDATIONS, INC.**  
**4810 POINT FOSDICK DRIVE NORTHWEST, PMB 60**  
**GIG HARBOR, WASHINGTON 98335**  
**(253) 858-8809**  
[www.pinfoundations.com](http://www.pinfoundations.com)

**Conditions of Use:**

1. The ICC-ES equivalency evaluation report (IRC) addresses only conformance with the IRC sections noted above.
2. The end use application of the schematic plans, details and tables in this report must be submitted to the code official for approval.
3. The exemptions for requirement to stamp the schematic plans, details and tables by a registered design professional must comply with the state license laws in which the project is to be constructed.
4. For use on projects defined in the equivalency evaluation subject in this EER. For projects outside this scope, contact Pin Foundations, Inc., for site specific engineering parameters.
5. This report applies only to the design parameters submitted for review by ICC-ES. Refer to Table 1 PFI Residential Diamond Pier Bearing Capacity Chart in this report for maximum bearing capacities and tributary load area.
6. The Diamond Pier DP50 & DP75 models defined in this report must be installed in accordance with the Pin Foundations, Inc. published Diamond Pier installation manual and Section 4.2 of ESR-1895.
7. If the presumptive soil capacity cannot be assumed in accordance with the IRC Table R401.4.1, the code official may request a soils report.
8. For specific sites where soil constituents, changing water levels or other factors that indicate possible deleterious effects of the soil strength may exist and presumptive soil values cannot be determined, verification of soil strength may require a soils investigation.
9. For conditions where uplift and lateral loading capacities are required, contact Pin Foundations, Inc., for 3<sup>rd</sup> party accredited testing reports.
10. For requirements on frost protection, see table below:

<b>Application/Use</b>	<b>Frost Protection Required?</b>	<b>Code Reference / Procedure</b>
Dettached acesory structures	No	R403.1.4.1 Exceptions 1 and 2 <sup>1</sup>
Exterior decks dettached to a dwelling	No	R403.1.4.1 Exceptions 3
Exterior decks attached to a dwelling	Yes	Refer to Pin Foundations installation manual for the proper size Diamond Pier model recommended for specific frost depth requirements

<sup>1</sup>Contact Pin Foundations Inc, when frost protection is required on conditions outside the scope of the code reference exceptions.

TABLE 1: PFI RESIDENTIAL DIAMOND PIER BEARING CAPACITY CHART

Minimum 1500 psf Silt/Clays (CL, ML, MH, CH) <sup>4</sup>	Model No. and Pin Length (inches) <sup>5</sup>	Allowable <sup>1</sup> Bearing Capacity (lbs)	Equivalent Base Area (sq. ft.)	Cylinder Comparison (inches)	Maximum Tributary Area in sq. ft. <sup>6</sup>			
					50 psf (total load) <sup>3</sup>	60 psf (total load) <sup>3</sup>	70 psf (total load) <sup>3</sup>	80 psf (total load) <sup>3</sup>
	DP50 - 36	2700	1.8	18	54	45	39	34
	DP50 - 42	3000 <sup>2</sup>	2.0	19	60	50	43	38
	DP50 - 50	3300 <sup>2</sup>	2.2	20	66	55	47	41
	DP75 - 50	3750 <sup>2</sup>	2.5	21	75	62	54	47
	DP75 - 63	4200	2.8	22	84	70	60	52
Equivalency to Traditional Concrete Footings								

Minimum 2000 psf Sands/Gravels (SW, SP, SM, SC, GM, GC) <sup>4</sup>	Model No. and Pin Length (inches) <sup>5</sup>	Allowable <sup>1</sup> Bearing Capacity (lbs)	Equivalent Base Area (sq. ft.)	Cylinder Comparison (inches)	Maximum Tributary Area in sq. ft. <sup>6</sup>			
					50 psf (total load) <sup>3</sup>	60 psf (total load) <sup>3</sup>	70 psf (total load) <sup>3</sup>	80 psf (total load) <sup>3</sup>
	DP50 - 36	3600	1.8	18	72	60	51	45
	DP50 - 42	4000 <sup>2</sup>	2.0	19	80	67	57	50
	DP50 - 50	4400	2.2	20	88	73	63	55
	DP75 - 50	5600 <sup>2</sup>	2.8	22	112	93	80	70
	DP75 - 63	6400	3.2	24	128	107	91	80
Equivalency to Traditional Concrete Footings								

<sup>1</sup>Capacities shown are tested to a Factor of Safety of 2, and are applicable in properly drained normal sound soils only, with minimum soil bearing capacities as indicated.

<sup>2</sup>Interpolated from tested values or conservatively derived from upper bound tested value.

<sup>3</sup>Total Load is based on highest load case: Dead + Live or Dead + Snow.

<sup>4</sup>For soils below 1500 psf, or soils with unknown characteristics, additional site and design analysis is required. For soils above 2000 psf, the values in this table shall apply.

<sup>5</sup>All capacities use four pins of the specified length per foundation. Pin length includes that portion of the pin embedded within the concrete head. See Figures 3 thru 6 for layouts and spacing restrictions.

<sup>6</sup>Maximum tributary area shown is for Diamond Pier bearing capacity only. See Figure 1 for determination of tributary areas. Tributary framing capacities shall comply with IRC requirements and may govern the design.

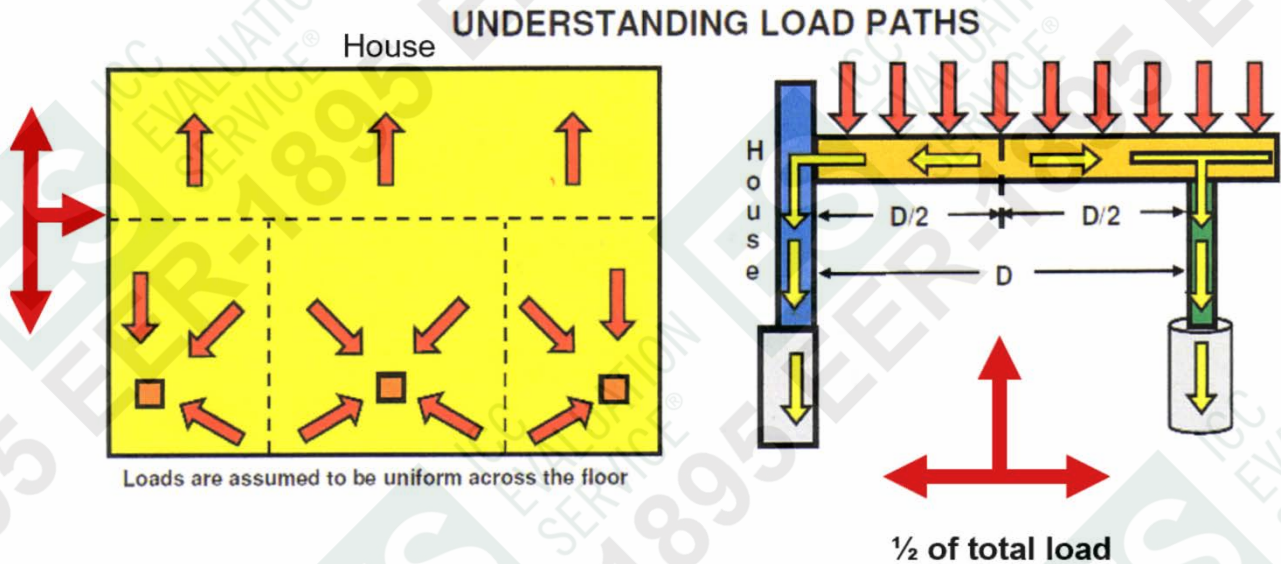
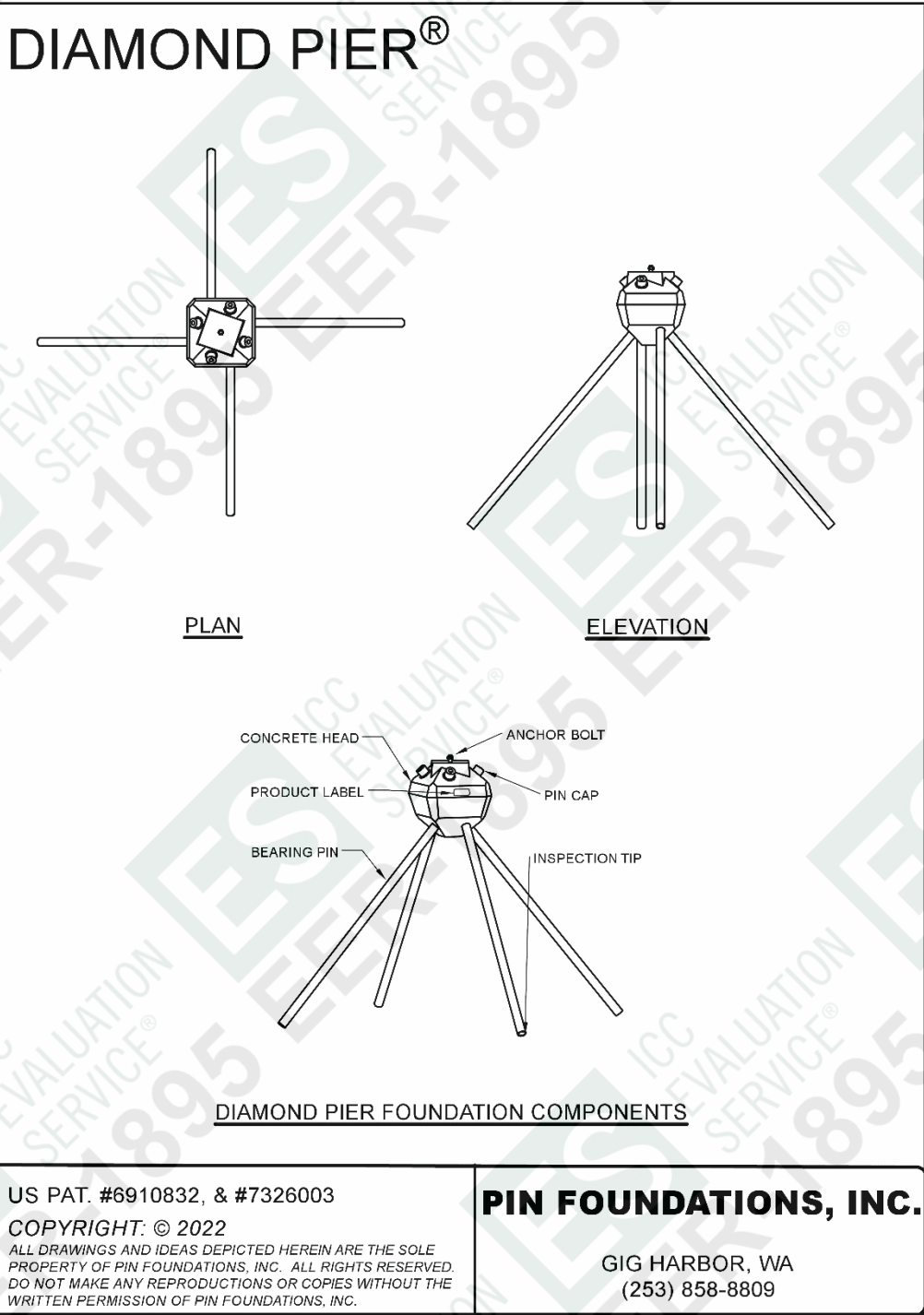
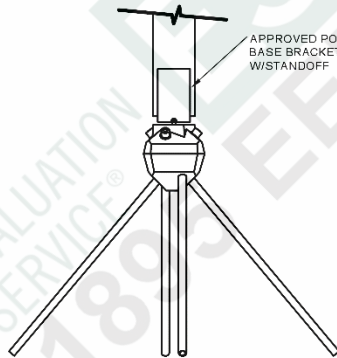

FIGURE 1: PLAN DIAGRAM

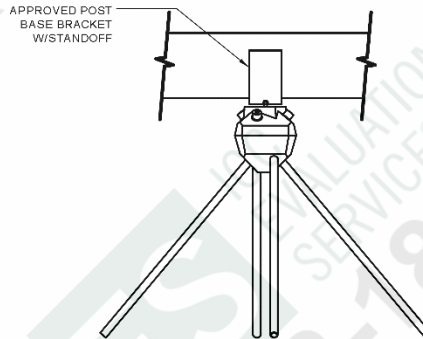

**FIGURE 2: COMPONENTS**

# DIAMOND PIER®



TYP POST CONNECTION



TYP BEAM CONNECTION

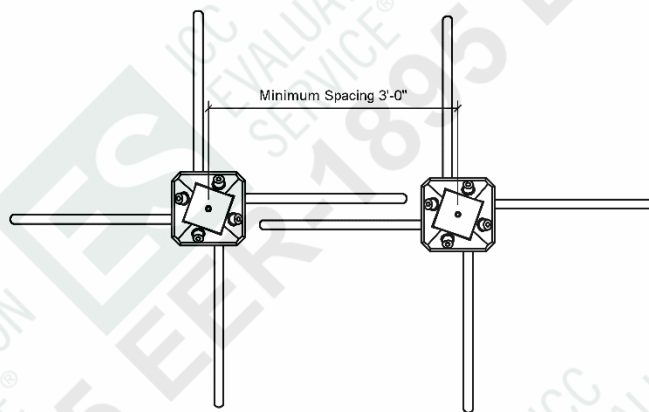

MINIMUM DISTANCE BETWEEN PIERS

US PAT. #6910832, & #7326003

COPYRIGHT: © 2022

ALL DRAWINGS AND IDEAS DEPICTED HEREIN ARE THE SOLE  
PROPERTY OF PIN FOUNDATIONS, INC. ALL RIGHTS RESERVED.  
DO NOT MAKE ANY REPRODUCTIONS OR COPIES WITHOUT THE  
WRITTEN PERMISSION OF PIN FOUNDATIONS, INC.

**PIN FOUNDATIONS, INC.**

GIG HARBOR, WA  
(253) 858-8809

**FIGURE 3: TYPICAL CONNECTIONS – MINIMUM SPACING**

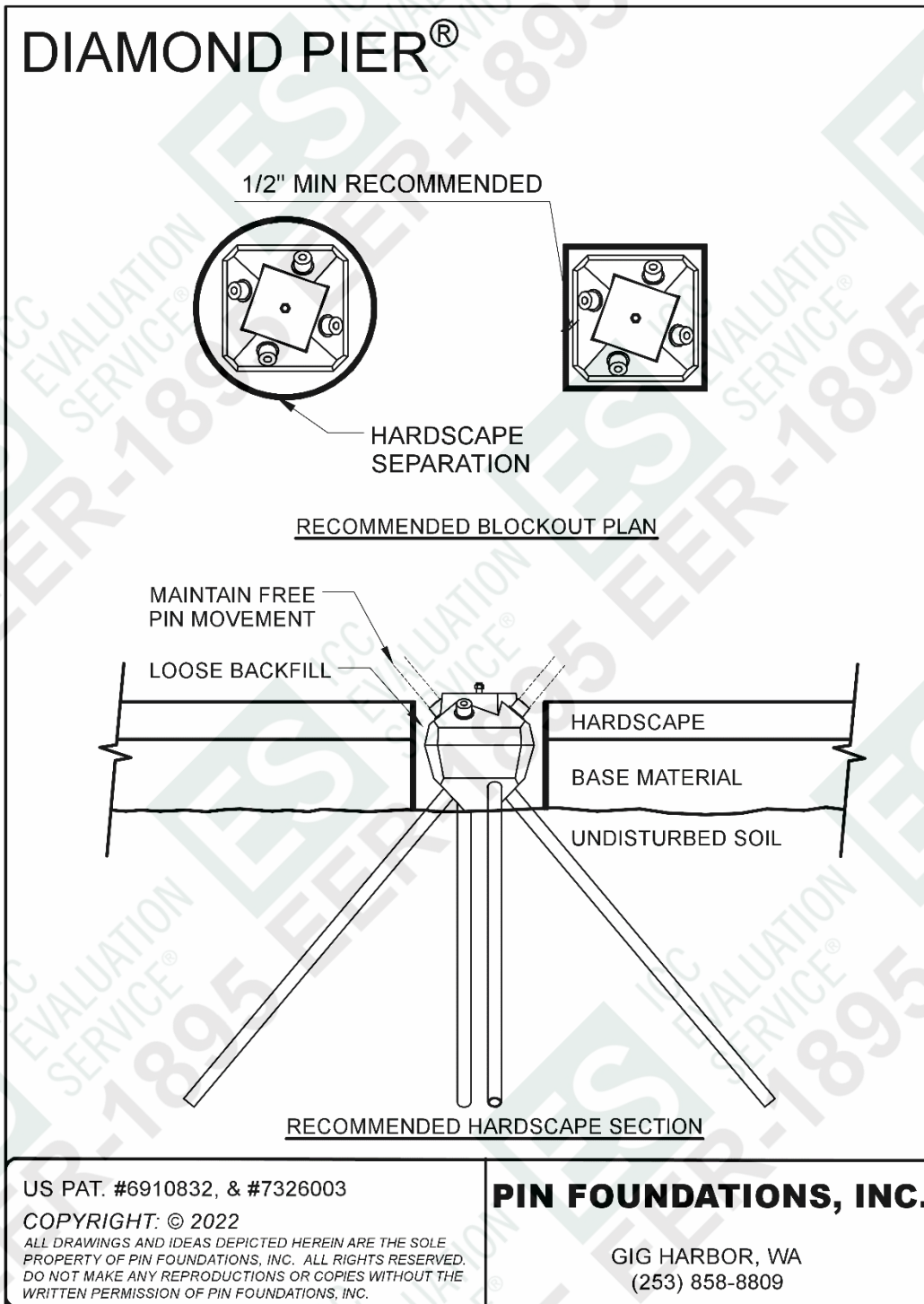

**FIGURE 4: HARDSCAPES DETAIL**

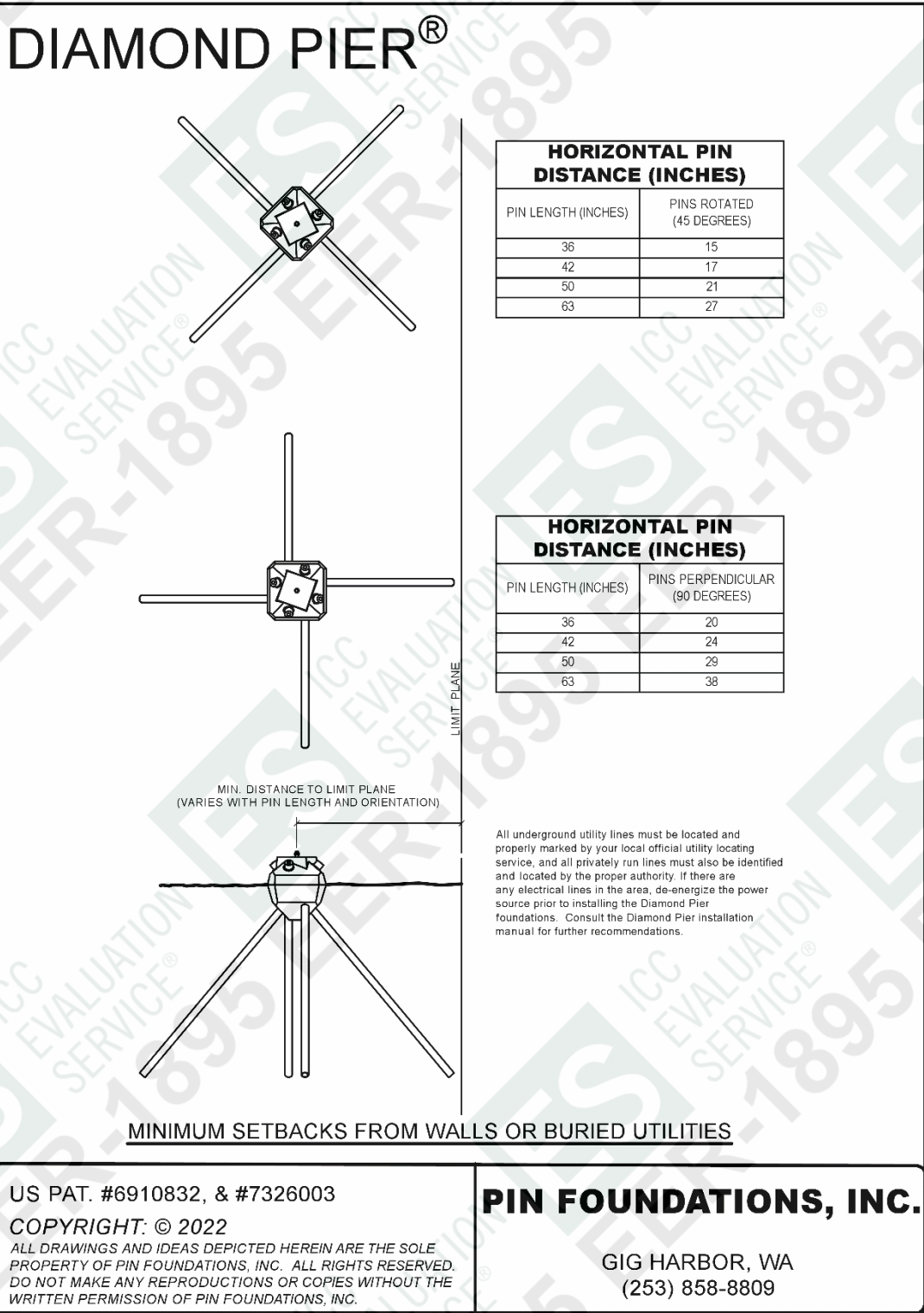

**FIGURE 5: LIMIT PLANE SETBACK**

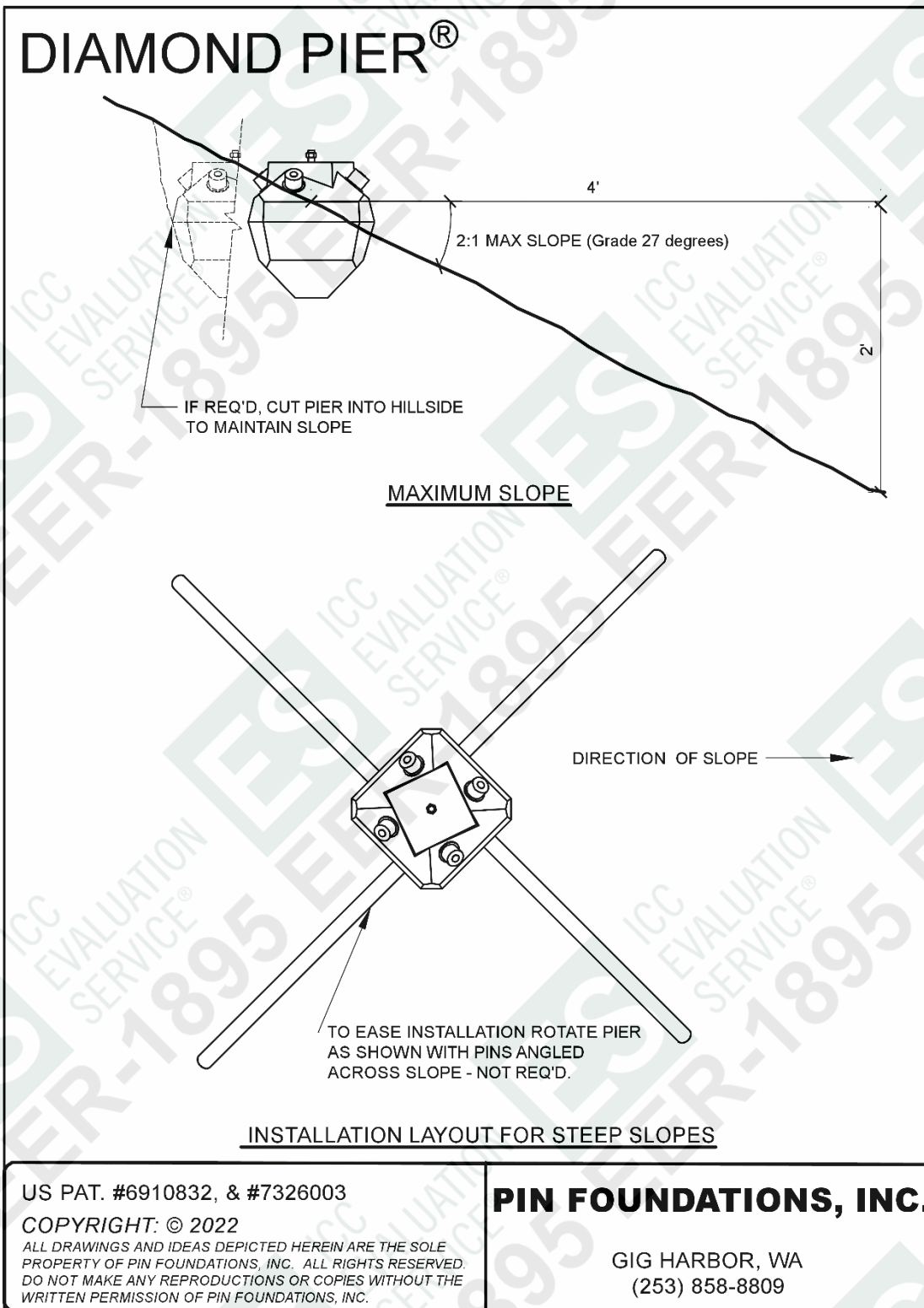

FIGURE 6: SLOPE DETAIL SETBACKS